

SW 32 Ti and SW 32.1 Ti Rotors



**Used in Beckman Coulter
Class H, R, and S
Preparative Ultracentrifuges**



SAFETY NOTICE

This safety notice summarizes information basic to the safe use of the rotors described in this manual. The international symbol displayed above is a reminder to the user that all safety instructions should be read and understood before operation or maintenance of this equipment is attempted. When you see the symbol on other pages throughout this publication, pay special attention to the specific safety information presented. Observance of safety precautions will also help to avoid actions that could damage or adversely affect the performance of the rotors. These rotors were developed, manufactured, and tested for safety and reliability as part of a Beckman Coulter ultracentrifuge/rotor system. Their safety or reliability cannot be assured if used in a centrifuge not of Beckman Coulter's manufacture or in a Beckman Coulter ultracentrifuge that has been modified without Beckman Coulter's approval.



Handle body fluids with care because they can transmit disease. No known test offers complete assurance that such fluids are free of micro-organisms. Some of the most virulent—Hepatitis (B and C) viruses, HIV (I–V), atypical mycobacteria, and certain systemic fungi—further emphasize the need for aerosol protection. Operator error or tube failure may generate aerosols. Do not run toxic, pathogenic, or other hazardous materials in this rotor unless you take all appropriate safety precautions. Handle all infectious samples according to good laboratory practices and methods to prevent the spread of disease. Ask your laboratory safety officer to advise you about the level of containment required for your application and about the proper decontamination or sterilization procedures to follow if fluids escape from containers. Biosafe containment should be used when Risk Group II materials (as identified in the World Health Organization *Laboratory Biosafety Manual*) are handled; materials of a higher group require more than one level of protection. Because spills may generate aerosols, observe proper safety precautions for aerosol containment.



The rotors and accessories are not designed for use with materials capable of developing flammable or explosive vapors. Do not centrifuge such materials in nor handle or store them near the centrifuge.



Although rotor components and accessories made by other manufacturers may fit in the SW 32 Ti and SW 32.1 Ti rotors, their safety in these rotors cannot be ascertained by Beckman Coulter. Use of other manufacturers' components or accessories in these rotors may void the rotor warranty and should be prohibited by your laboratory safety officer. Only the components and accessories listed in this publication should be used in this rotor.



Attach all six buckets, loaded or empty, to the rotor for every run. Make sure that filled containers are loaded symmetrically into the rotor and that opposing tubes are filled to the same level with liquid of the same density. Make sure that buckets containing Quick-Seal tubes have the proper floating spacers inserted (if applicable) before installing the bucket cap.



Never exceed the maximum rated speed of the rotor and labware in use. Refer to the section on RUN SPEEDS.



If disassembly reveals evidence of leakage, you should assume that some fluid escaped the rotor. Apply appropriate decontamination procedures to the centrifuge and accessories as required.



Do not use sharp tools on the rotor that could cause scratches in the rotor surface. Corrosion begins in scratches and may open fissures in the rotor with continued use.

SW 32 Ti ROTOR

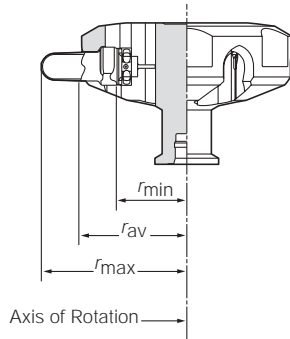

SW 32.1 Ti ROTOR

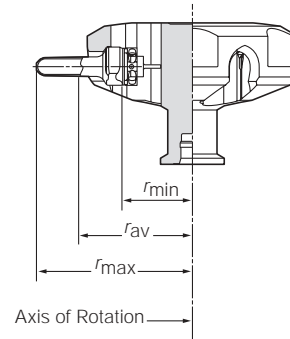

SPECIFICATIONS

SW 32 Ti

Maximum speed	32 000 rpm
Density rating at maximum speed	1.2 g/mL
Relative Centrifugal Field* at maximum speed	
at r_{max} (152.5 mm)	175 000 × g
at r_{av} (109.7 mm)	126 000 × g
at r_{min} (66.8 mm)	76 600 × g
k factor at maximum speed	204
k' factors at maximum speed (5 to 20% sucrose gradient; 5°C)	
When particle density = 1.3 g/mL	468
When particle density = 1.5 g/mL	428
When particle density = 1.7 g/mL	412
Conditions requiring speed reduction	see RUN SPEEDS
Number of buckets	6
Available tubes	see Table 1
Nominal tube dimensions	
(largest tube)	25 × 89 mm
Nominal tube capacity (largest tube)	38.5 mL
Nominal rotor capacity	231 mL
Approximate acceleration time to maximum speed (rotor fully loaded)	6 3/4 min
Approximate deceleration time from maximum speed (rotor fully loaded)	9 1/2 min
Weight of fully loaded rotor	8.5 kg (18.7 lb)
Rotor and bucket material	titanium

SW 32.1 Ti

Maximum speed	32 000 rpm
Density rating at maximum speed	1.2 g/mL
Relative Centrifugal Field* at maximum speed	
at r_{max} (162.8 mm)	187 000 × g
at r_{av} (113.6 mm)	130 000 × g
at r_{min} (64.4 mm)	73 900 × g
k factor at maximum speed	228
k' factors at maximum speed (5 to 20% sucrose gradient; 5°C)	
When particle density = 1.3 g/mL	613
When particle density = 1.5 g/mL	560
When particle density = 1.7 g/mL	536
Conditions requiring speed reduction	see RUN SPEEDS
Number of buckets	6
Available tubes	see Table 2
Nominal tube dimensions	
(largest tube)	16 × 102 mm
Nominal tube capacity (largest tube)	17 mL
Nominal rotor capacity	102 mL
Approximate acceleration time to maximum speed (rotor fully loaded)	6 1/2 min
Approximate deceleration time from maximum speed (rotor fully loaded)	9 1/4 min
Weight of fully loaded rotor	8.3 kg (18.3 lb)
Rotor and bucket material	titanium

* Relative Centrifugal Field (RCF) is the ratio of the centrifugal acceleration at a specified radius and speed ($r\omega^2$) to the standard acceleration of gravity (g) according to the following formula:

$$RCF = \frac{r\omega^2}{g}$$

where r is the radius in millimeters, ω is the angular velocity in radians per second ($2\pi \text{ RPM} / 60$), and g is the standard acceleration of gravity (9807 mm/s²). After substitution:

$$RCF = 1.12 r \left(\frac{\text{RPM}}{1000} \right)^2$$

DESCRIPTION

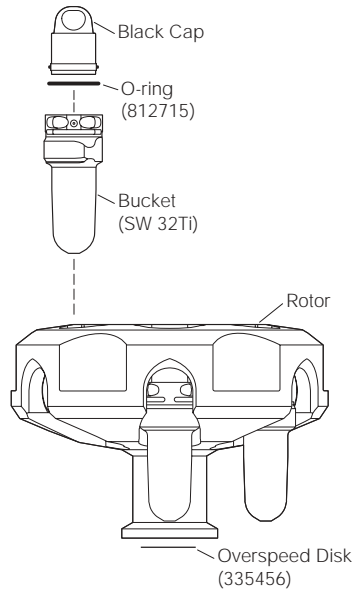

These rotors have been manufactured in an NSAI-registered ISO 9001 or 9002 facility for use with the appropriately classified Beckman Coulter ultracentrifuges.

The SW 32 Ti and SW 32.1 Ti, both rated for 32 000 rpm, are swinging bucket rotors designed to centrifuge up to six tubes each. Used in Beckman Coulter class H, R, and S preparative ultracentrifuges, these rotors develop centrifugal forces for the separation of subcellular particles and viruses in density gradients. The rotors have a common rotor body with buckets that can be used interchangeably (see ROTOR PREPARATION). Bucket and rotor body positions are numbered for operator convenience.

The rotor body and buckets are made of titanium, finished with polyurethane paint. Bucket caps are made of aluminum, anodized for corrosion resistance. Each bucket and cap assembly sets into grooves in the rotor body. O-rings, made of Buna N rubber, between each bucket and bucket cap maintain atmospheric pressure inside the buckets during centrifugation.

For overspeed protection, a Beckman Coulter ultracentrifuge equipped with a photoelectric detector will monitor the overspeed disk on the rotor bottom and shut down the run if a speed exceeding the maximum allowable run speed is detected.

For warranty information, see the WARRANTY at the back of this manual.

PREPARATION AND USE

Specific information about the SW 32 Ti and SW 32.1 Ti rotors is given here. Information common to these and other rotors is contained in the manual Rotors and Tubes for Preparative Ultracentrifuges (publication LR-IM), which should be used together with this manual for complete rotor and accessory operation.

NOTE

Although rotor components and accessories made by other manufacturers may fit in the SW 32 Ti and SW 32.1 Ti rotors, their safety in these rotors cannot be ascertained by Beckman Coulter. Use of other manufacturers' components or accessories in these rotors may void the rotor warranty and should be prohibited by your laboratory safety officer. Only the components and accessories listed in this publication should be used in these rotors.

PRERUN SAFETY CHECK

Read the Safety Notice page at the front of this manual before using the rotor.



1. Make sure that the rotor, buckets, and caps are clean and show no sign of corrosion or cracking.
2. Make sure that the rotor is equipped with the correct overspeed disk. If the disk is missing or damaged, replace it according to the instructions in *Rotors and Tubes*.
3. Check the chemical compatibilities of all materials used (refer to Appendix A in *Rotors and Tubes*).
4. Verify that the tubes and bottles being used are listed in Table 1 or Table 2.

ROTOR PREPARATION

For runs at other than room temperature, refrigerate or warm the rotor beforehand for fast equilibration.

NOTE

Place the rotor on the rotor stand (332400) when it is not in the centrifuge. Take care to protect the overspeed disk from damage when handling the rotor.

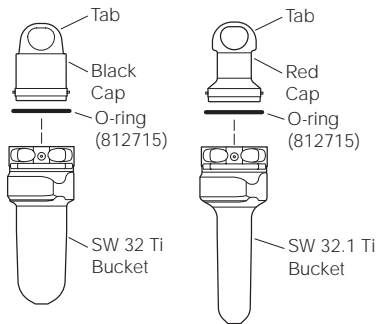

1. Install the rotor body on the drive hub. Slowly turn the rotor to the right (clockwise) to make sure it is properly seated.
2. Load the filled containers into the buckets (see page 8 for tube information). Complete loading by placing the correct floating spacers (if required) over the tubes.
3. Ensure that bucket O-rings are lightly but evenly coated with silicone vacuum grease (335148). Do not run a bucket without an O-ring, as the bucket will leak.



CAUTION

Use only black caps (369643) on black SW 32 Ti buckets and red caps (369645) on red SW 32.1 Ti buckets.

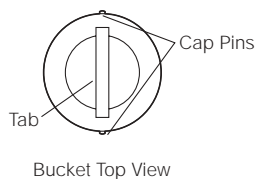

Bucket Top View

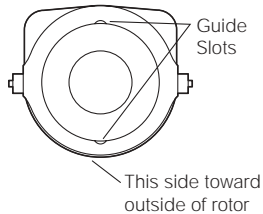

4. Use a lint-free cotton swab to apply Spinkote™ lubricant (396812) to cap grooves in the bucket tops. Match bucket caps with numbered buckets. Align the pins on each side of the cap with the guide slots in the bucket. Twist the cap clockwise until it stops (one-quarter turn).
5. Grasp the bucket cap tabs and lower the buckets into the openings on the rotor body with the rounded sides toward the outside of the rotor.

NOTE

A bucket will not seat in the rotor if it is inserted in the rotor with the rounded side toward the rotor center. The bucket will fall through, spilling or disturbing the tube contents.

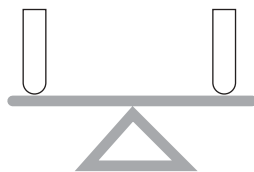

Six bucket assemblies must be installed, whether loaded or empty. If fewer than six tubes are being run, they must be arranged symmetrically in the rotor (see Figure 1). Opposing tubes must be filled to the same level with liquid of the same density.

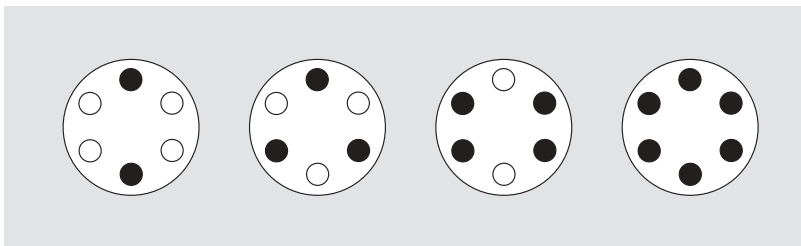

*Figure 1. Arranging Tubes Symmetrically in the Rotor Buckets.
Two, three, four, or six tubes can be centrifuged per run
if they are arranged in the rotor as shown.
All bucket assemblies must be attached to the rotor,
whether loaded or empty.*

OPERATION

1. For low-temperature runs, precool the buckets in the centrifuge or in a refrigerator before use—especially before short runs—to ensure that they reach the set temperature. A suggested precooling cycle is a minimum of 30 minutes at 2000 rpm at the required temperature.
2. Refer to the centrifuge instruction manual for additional operating instructions.

For additional information, see the following:

- RUN TIMES, page 12, for using k factors to adjust run durations,
- RUN SPEEDS, page 13, for information about speed limitations, and
- SELECTING CsCl GRADIENTS, page 15, for methods to avoid CsCl precipitation during centrifugation.

REMOVAL AND SAMPLE RECOVERY



CAUTION

If disassembly reveals evidence of leakage, you should assume that some fluid escaped the rotor. Apply appropriate decontamination procedures to the centrifuge and accessories as required.

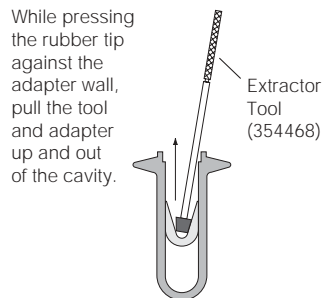

1. Grasp the bucket cap tabs and lift up to remove the buckets. (Buckets may be removed without removing the rotor body from the ultracentrifuge.)
2. Remove the bucket caps by twisting counterclockwise and lifting up. Use a tube removal tool (361668) or hemostat to remove the spacers and tubes.

NOTE

If the conical-shaped adapters that support *konikal*TM tubes are difficult to remove after centrifugation, an extractor tool (354468) is available to facilitate removal.

3. To remove the rotor from the centrifuge, lift the rotor straight up and off the drive hub. Set the rotor on the rotor stand.

TUBES AND ACCESSORIES

The SW 32 Ti rotor uses tubes and accessories listed in Table 1; the SW 32.1 Ti rotor uses tubes and accessories listed in Table 2. Be sure to use only those items listed, and to observe the maximum speed limits shown. Refer to Appendix A in *Rotors and Tubes* for information on the chemical resistances of tube and accessory materials.

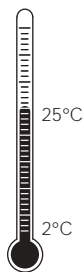

Temperature Limit

- Plastic tubes and bottles have been tested for use at temperatures between 2 and 25°C. For centrifugation at other temperatures, pretest tubes under anticipated run conditions.
- If plastic containers are frozen before use, make sure that they are thawed to 2°C or warmer prior to centrifugation.

Table 1. Beckman Coulter Tubes and Accessories for the SW 32 Ti Rotor. Use only the items listed here.

Tube			Required Accessory		Max Speed/ RCF/ k Factor
Dimensions and Volume	Description	Part Number	Description	Part Number	
25 × 89 mm 38.5 mL	Ultra-Clear™ open-top	344058 (pkg/50)	none	—	32 000 rpm 175 000 × g 204
25 × 89 mm 38.5 mL	polyallomer open-top	326823 (pkg/50)	none	—	32 000 rpm 175 000 × g 204
25 × 89 mm 31 mL	thickwall polyallomer open-top	355642 (pkg/25)	none	—	32 000 rpm 175 000 × g 198
25 × 89 mm 31 mL	thickwall polycarbonate open-top	355631 (pkg/25)	none	—	32 000 rpm 175 000 × g 202
25 × 83 mm 33.5 mL	polyallomer Quick-Seal, bell-top	344623 (pkg/50)	Noryl* floating spacer	355536	32 000 rpm 175 000 × g 192
25 × 89 mm 31.5 mL	konical polyallomer open-top	358126 (pkg/50)	Hytrel† adapter	358156 (pkg/6)	32 000 rpm 175 000 × g 199
25 × 83 mm 28 mL	konical polyallomer Quick-Seal, bell-top	358651 (pkg/50)	adapter	358156	32 000 rpm 175 000 × g 198
			Noryl floating spacer	355536	
25 × 76 mm 25.5 mL	konical polyallomer open-top	358125 (pkg/50)	Hytrel adapter	358156 (pkg/6)	32 000 rpm 175 000 × g 156
25 × 64 mm 27 mL	polyallomer Quick-Seal, bell-top	343665 (pkg/50)	Noryl floating spacer	355536	32 000 rpm 175 000 × g 146
25 × 77 mm 32.4 mL	OptiSeal™ bell-top‡	361625 (pkg/56)	Ultem* spacer	392833	32 000 rpm 175 000 × g 155
25 × 38 mm 15 mL	polyallomer Quick-Seal, bell-top	343664 (pkg/50)	Noryl floating spacer	355536	32 000 rpm 175 000 × g 81
25 × 38 mm 8.4 mL	konical polyallomer Quick-Seal, bell-top	358652 (pkg/50)	Hytrel adapter	358156 (pkg/6)	32 000 rpm 175 000 × g 74
			Noryl floating spacer	355536	
25 × 76 mm 22.5 mL	konical polyallomer Quick-Seal, bell-top	358654 (pkg/50)	Hytrel adapter	358156	32 000 rpm 175 000 × g 155
			Noryl floating spacer	355536	

*Noryl and Ultem are registered trademarks of GE Plastics.

†Hytrel is a registered trademark of E.I. Du Pont de Nemours and Company.

‡Includes disposable plastic plugs.

Table 2. Beckman Coulter Tubes and Accessories for the SW 32.1 Ti Rotor.
Use only the items listed here.

Tube			Required Accessory		Max Speed/ RCF/ k Factor
Dimensions and Volume	Description	Part Number	Description	Part Number	
16 × 102 mm 14.5 mL	polyallomer Quick-Seal, bell-top	356291 (pkg/50)	Noryl floating spacer	355579	32 000 rpm 187 000 × <i>g</i> 199
16 × 102 mm 17 mL	Ultra-Clear, open-top	344061 (pkg/50)	none	—	32 000 rpm 187 000 × <i>g</i> 228
16 × 102 mm 12.5 mL	konical polyallomer Quick-Seal, bell-top	358653 (pkg/50)	adapter	358155	32 000 rpm 187 000 × <i>g</i> 205
			Noryl floating spacer	355579	
16 × 96 mm 16.5 mL	polyallomer, open-top	337986 (pkg/50)	none	—	32 000 rpm 187 000 × <i>g</i> 228
16 × 93 mm 13.5 mL	konical polyallomer, open-top	358123 (pkg/50)	Hytrel adapter	358155	32 000 rpm 187 000 × <i>g</i> 225
16 × 67 mm 10.5 mL	polyallomer Quick-Seal, bell-top	344622 (pkg/50)	Noryl floating spacer	355579	32 000 rpm 187 000 × <i>g</i> 133
16 × 57 mm 8 mL	polyallomer Quick-Seal, bell-top	344621 (pkg/50)	Noryl floating spacer	355579	32 000 rpm 187 000 × <i>g</i> 102
16 × 44 mm 6.5 mL	polyallomer Quick-Seal, bell-top	345830 (pkg/50)	Noryl floating spacer	355579	32 000 rpm 187 000 × <i>g</i> 79
16 × 32 mm 4.5 mL	polyallomer Quick-Seal, bell-top	356562 (pkg/50)	Noryl floating spacer	355579	32 000 rpm 187 000 × <i>g</i> 56

OptiSeal™ Tubes

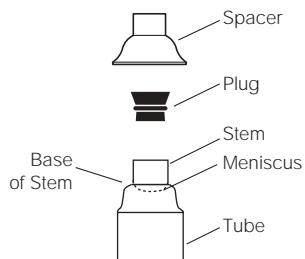

OptiSeal tubes come with plastic plugs and can be quickly and easily prepared for use. With the tube spacer in place, the g force during centrifugation ensures a tight, reliable seal that protects your samples.

- Place the tubes in the rack and fill each tube to the base of the stem, leaving no fluid in the stem. Overfilling the tube can cause spillage when the plug is inserted or can compromise seal integrity. However, too much air can cause excessive tube deformation, disrupting gradients and sample bands.
- Refer to *Using OptiSeal™ Tubes* (publication IN-189), included in each box of tubes, for detailed information on the use and care of OptiSeal tubes.

Quick-Seal® Tubes



Quick-Seal tubes must be sealed prior to centrifugation. These tubes are heat sealed and do not need caps; however, spacers are required on top of the tubes when they are loaded into the rotor buckets.

- Fill Quick-Seal tubes leaving a small bubble of air at the base of the neck. Do not leave large air space—too much air can cause excessive tube deformation.
- Refer to *Rotors and Tubes* for detailed information on the use and care of Quick-Seal tubes.

Some of the tubes listed in Tables 1 and 2 are part of the g -Max™ system, which uses a combination of small bell-top Quick-Seal tubes and floating spacers (also called g -Max spacers). This means that you can run the shorter tubes listed in the tables in the SW 32 Ti and SW 32.1 Ti rotors without reduction in g force. Additional information about the g -Max system is available in publication DS-709.

konical™ Tubes

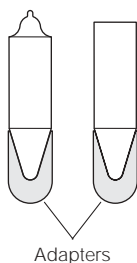

Polyallomer *konical* tubes, used to optimize pelleting separations, have a conical tip that concentrates the pellet in the narrow end of the tube. The narrow bottom also reduces the tube's nominal volume and minimizes gradient material requirement. The *konical* tubes come in both open-top and Quick-Seal tube designs. Conical cavity adapters hold the tubes in the rotor buckets.



Polyallomer and Ultra-Clear® Open-Top Tubes

Polyallomer and Ultra-Clear open-top tubes should be filled to 2 or 3 mm from the tube top for tube support. If necessary, float mineral oil (or some other low-density, immiscible liquid) on top of the tube contents to fill the tube to its maximum volume. (Do not use an oil overlay in Ultra-Clear tubes.) All opposing tubes for a run must be filled to the same level with liquid of the same density.

RUN TIMES

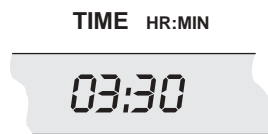

The k factor of the rotor is a measure of the rotor's pelleting efficiency. (Beckman Coulter has calculated the k factors for all of its rotors at maximum speed and using full tubes.) The k factor is calculated from the formula:

$$k = \frac{\ln(r_{\max}/r_{\min})}{\omega^2} \times \frac{10^{13}}{3600} \quad (1)$$

where ω is the angular velocity of the rotor in radians per second ($\omega = 0.105 \times \text{rpm}$), r_{\max} is the maximum radius, and r_{\min} is the minimum radius.

After substitution:

$$k = \frac{(2.533 \times 10^{11}) \ln(r_{\max}/r_{\min})}{\text{rpm}^2} \quad (2)$$

Use the k factor in the following equation to estimate the run time t (in hours) required to pellet particles of known sedimentation coefficient s (in Svedberg units, S).

$$t = \frac{k}{s} \quad (3)$$

Run times can be estimated for centrifugation at less than maximum speed by adjusting the k factor as follows:

$$k_{\text{adj}} = k \left(\frac{32\,000}{\text{actual run speed}} \right)^2 \quad (4)$$

Run times can also be estimated from data established in prior experiments if the k factor of the previous rotor is known. For any two rotors, a and b:

$$\frac{t_a}{t_b} = \frac{k_a}{k_b} \quad (5)$$

where the k factors have been adjusted for the actual run speed used.

For more information on k factors, see *Use of k Factor for Estimating Run Times from Previously Established Run Conditions* (publication DS-719).

RUN SPEEDS

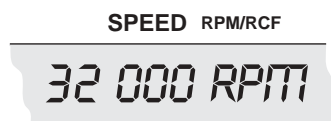

The centrifugal force at a given radius in a rotor is a function of speed. Comparisons of forces between different rotors are made by comparing the rotors' relative centrifugal fields (RCF). When rotational speed is selected so that identical samples are subjected to the same RCF in two different rotors, the samples are subjected to the same force. The RCF at a number of rotor speeds is provided in Table 3.

Do not select run speeds in excess of 32 000 rpm. In addition, speeds must be reduced under the following circumstances:

1. If nonprecipitating solutions more dense than 1.2 g/mL are centrifuged, reduce the maximum allowable run speed according to the following equation:

$$\text{reduced maximum speed} = (32\,000 \text{ rpm}) \sqrt{\frac{1.2 \text{ g/mL}}{\rho}} \quad (6)$$

where ρ is the density of the tube contents. This speed reduction will protect the rotor from excessive stresses due to the added tube load.

2. *Further speed limits must be imposed* when CsCl or other self-forming-gradient salts are centrifuged, as equation (6) does not predict concentration limits/speeds that are required to prevent precipitation of salt crystals. Solid CsCl has a density of 4 g/mL, and if precipitated during centrifugation may cause rotor failure. Figures 2 through 5, together with the description and examples below, show how to reduce run speeds when using CsCl gradients.

Table 3. Relative Centrifugal Fields for the SW 32 Ti and SW 32.1 Ti Rotors.
 Entries in this table are calculated from the formula $RCF = 1.12r (RPM/1000)^2$
 and are then rounded to three significant digits.

SW 32 Ti Rotor				SW 32.1 Ti Rotor			
Rotor Speed (rpm)	Relative Centrifugal Field (× g)			Rotor Speed (rpm)	Relative Centrifugal Field (× g)		
	At r_{max} (152.5 mm)	At r_{av} (109.7 mm)	At r_{min} (66.8 mm)		At r_{max} (162.8 mm)	At r_{av} (113.6 mm)	At r_{min} (64.4 mm)
32 000	175 000	126 000	76 600	32 000	187 000	130 000	73 900
30 000	154 000	111 000	67 300	30 000	164 000	115 000	65 000
25 000	107 000	76 800	46 800	25 000	114 000	80 000	45 100
20 000	68 300	49 200	29 900	20 000	73 000	50 900	28 900
15 000	38 400	27 600	16 800	15 000	41 000	28 600	16 200
10 000	17 100	12 300	7 480	10 000	18 200	12 700	7 210
5 000	4 270	3 070	1 870	5 000	4 560	3 180	1 800
500	43	31	19	500	46	32	18

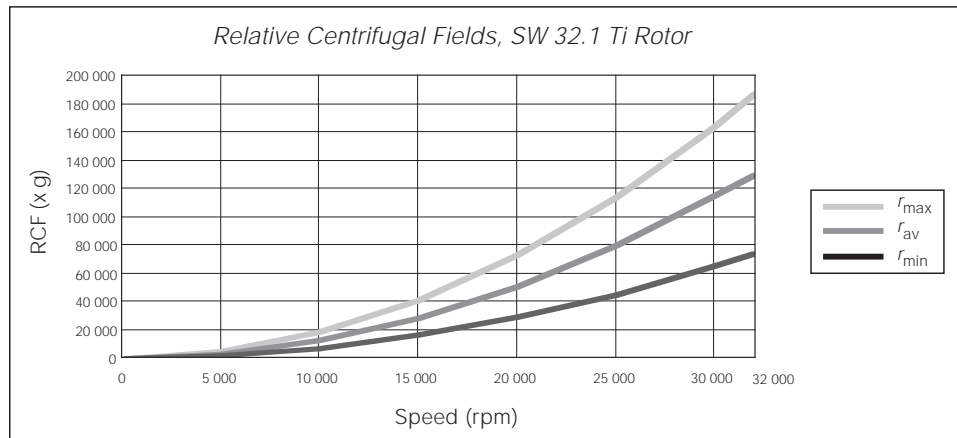
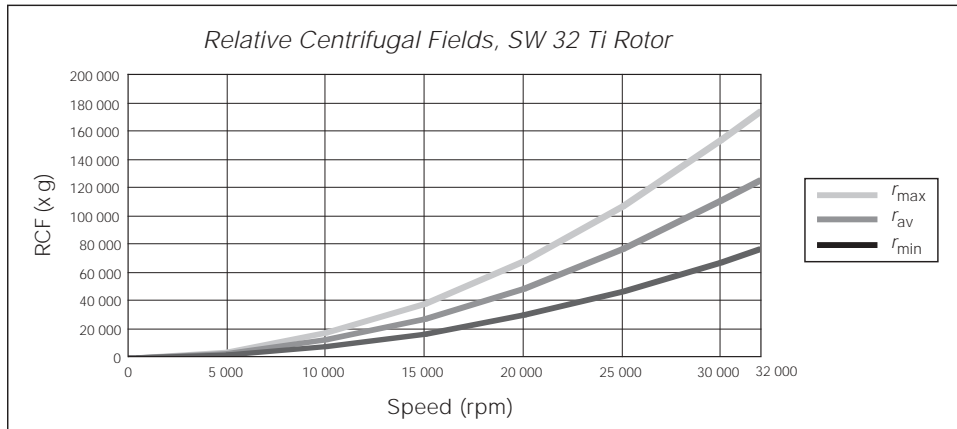

SELECTING CsCl GRADIENTS

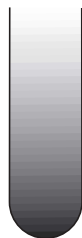

Rotor speed is used to control the slope of a CsCl density gradient, and must be limited to prevent CsCl precipitation during centrifugation. Speed and density combinations that intersect on or below the curves in Figure 2 (for the SW 32 Ti rotor) and in Figure 4 (for the SW 32.1 Ti rotor) ensure that CsCl will not precipitate during centrifugation in these rotors. Curves are provided at two temperatures: 20°C (black curves) and 4°C (gray curves). Curves in Figures 2 through 5 are provided up to the maximum speed of the rotor.

NOTE

The curves in Figures 2 through 5 are for solutions of CsCl salt dissolved in distilled water only. If other salts are present in significant concentrations, the overall CsCl concentration may need to be reduced.

The reference curves shown in Figures 3 and 5 show gradient distribution at equilibrium. Each curve in Figure 3 is within the density limits allowed for the SW 32 Ti rotor; each curve in Figure 5 is within the density limits allowed for the SW 32.1 Ti rotor. Each curve was generated for a single run speed using the maximum allowable homogeneous CsCl densities (one for each fill level) that avoid precipitation at that speed. (The gradients in Figures 3 and 5 can be generated from step or linear gradients, or from homogeneous solutions. But the total amount of CsCl in solution must be equivalent to a homogeneous solution corresponding to the concentrations specified in Figures 3 and 5.) Figures 3 and 5 can also be used to approximate the banding positions of sample particles. Curves not shown may be interpolated.

ADJUSTING FILL VOLUMES

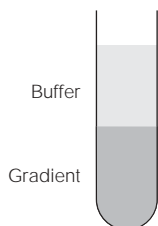

Figures 2 through 5 show that several fill volumes are possible in a tube. If a thinwall tube is partially filled with gradient solution, float mineral oil (or some other low-density, immiscible liquid) on top of the tube contents to fill the tube to its maximum volume. (Do not use an oil overlay in Ultra-Clear tubes.) Note that for a given CsCl density, as the fill level decreases the maximum allowable speed increases. Partial filling may be desirable when there is little sample or when you wish to shorten the run time.

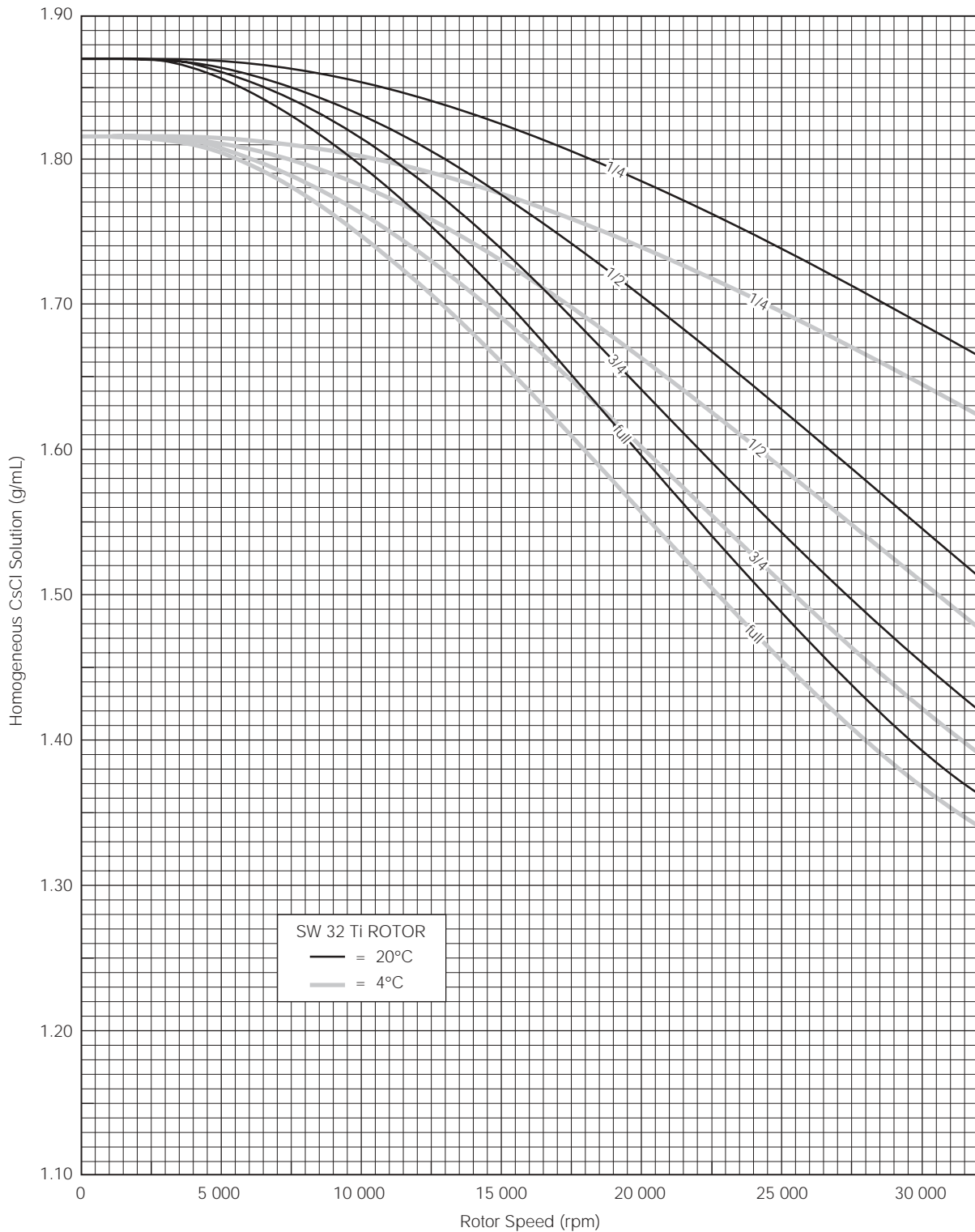

Figure 2. Precipitation Curves for the SW 32 Ti Rotor.
 Using speed and density combinations that intersect on or below the solid curves ensures that CsCl will not precipitate during centrifugation. Tube fill volumes are indicated on the curves.

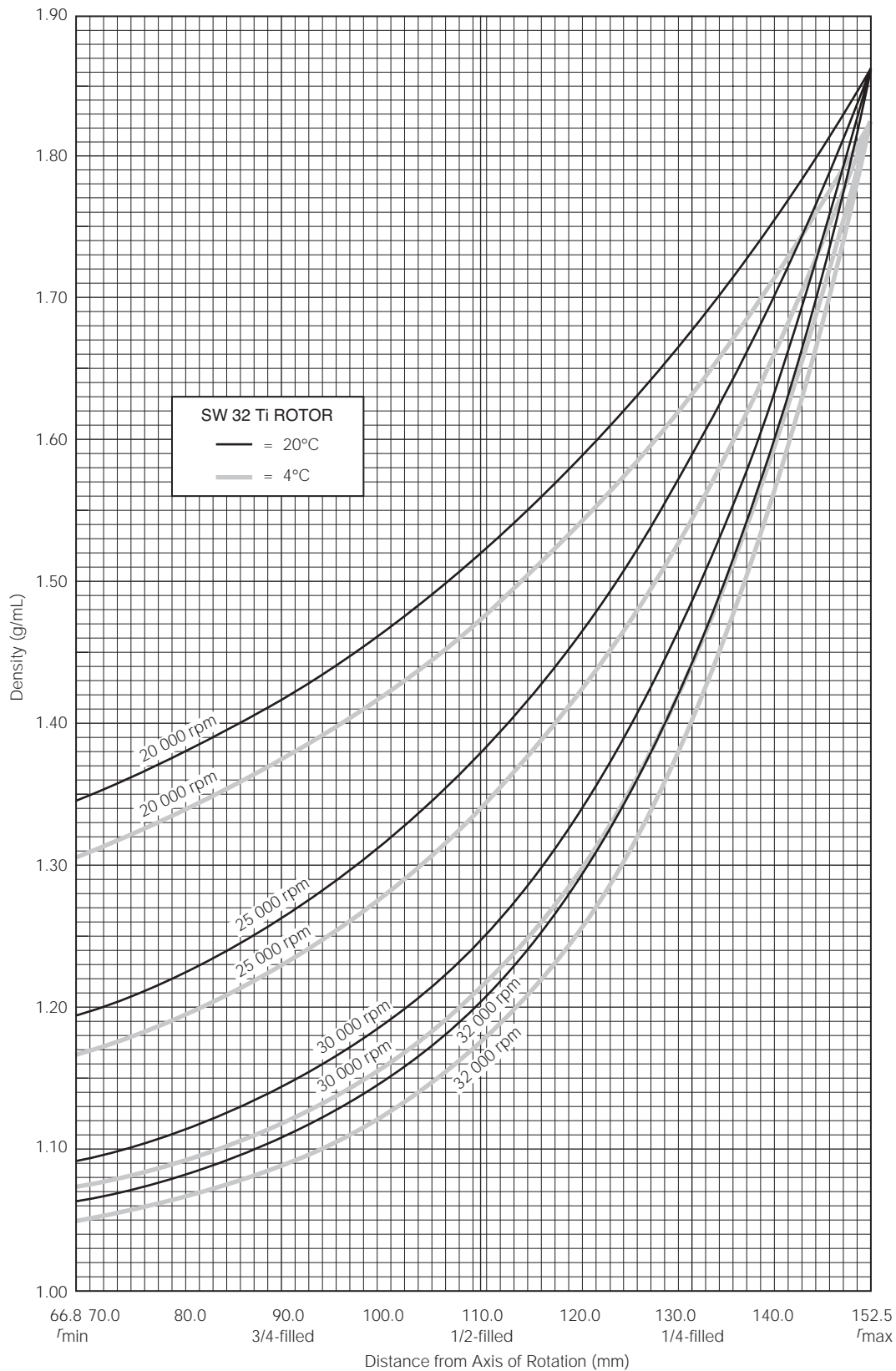

Figure 3. CsCl Gradients at Equilibrium for the SW 32 Ti Rotor. Centrifugation of homogeneous CsCl solutions at maximum allowable speeds (from Figure 2) results in gradients presented here.

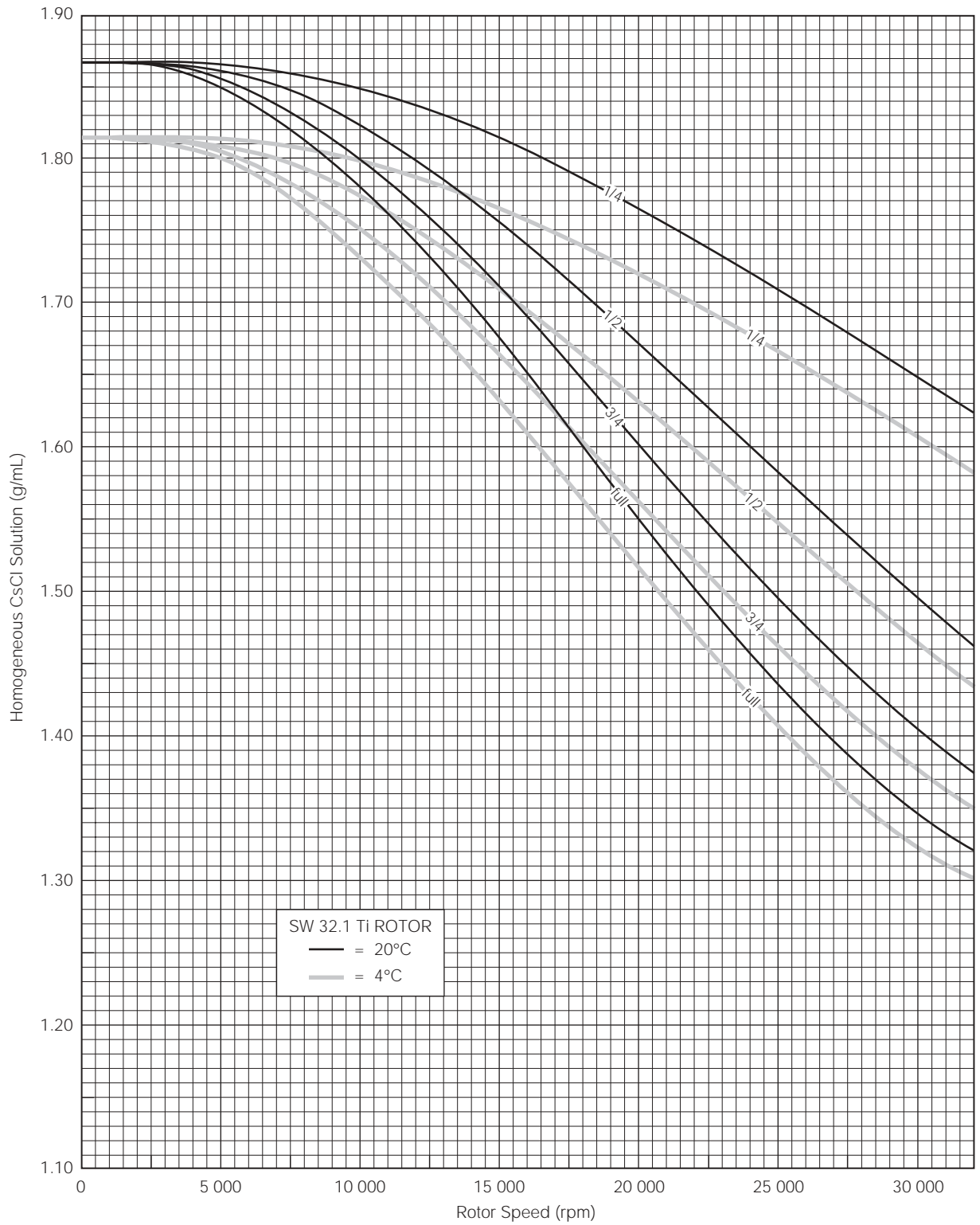

Figure 4. Precipitation Curves for the SW 32.1 Ti Rotor.
 Using speed and density combinations that intersect on or below the solid curves ensures that CsCl will not precipitate during centrifugation. Tube fill volumes are indicated on the curves.

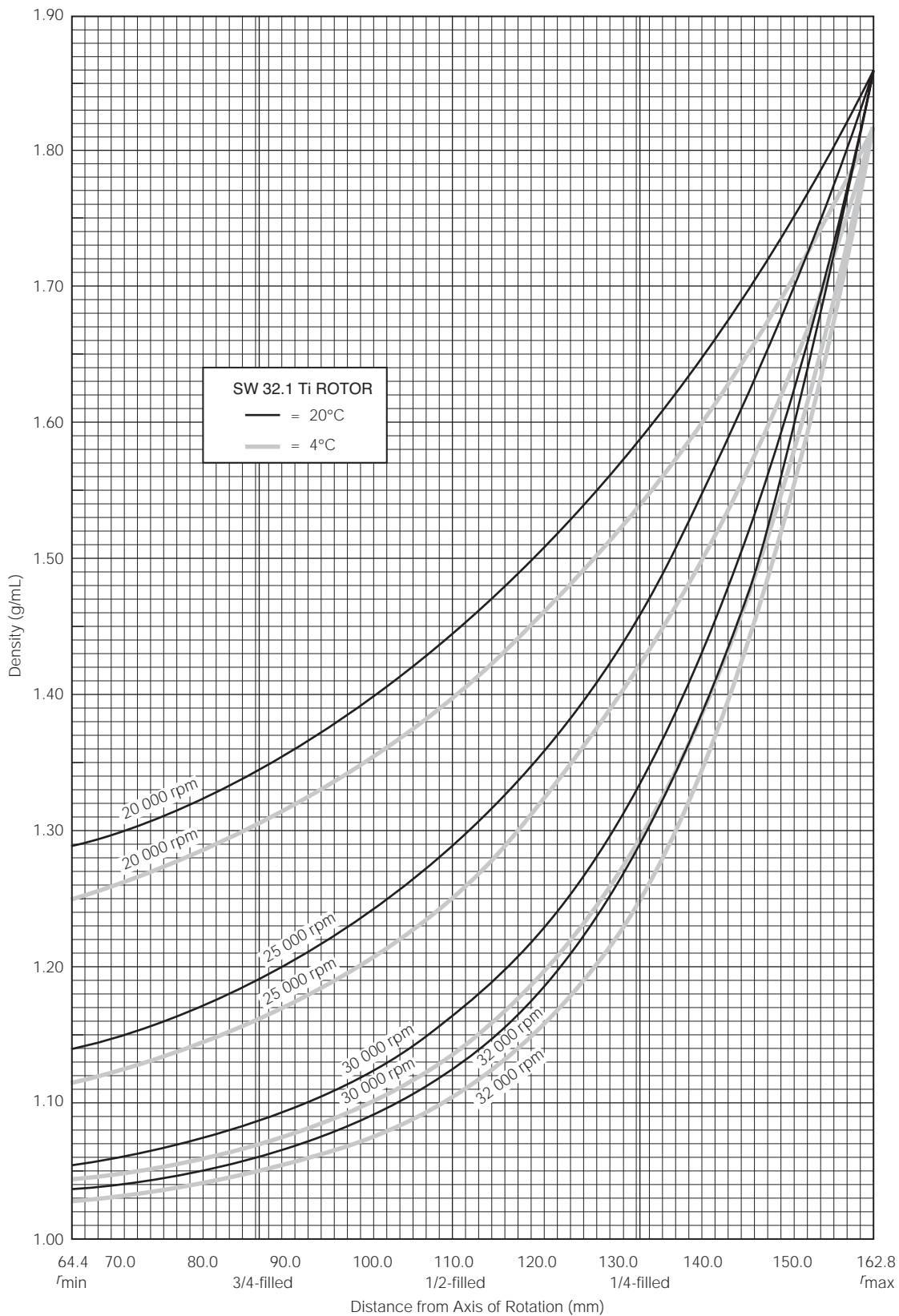
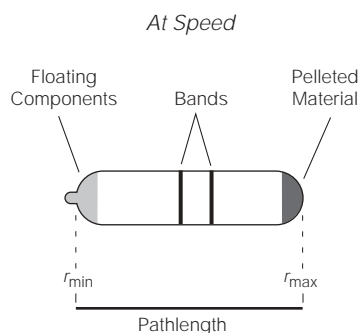

Figure 5. CsCl Gradients at Equilibrium for the SW 32.1 Ti Rotor. Centrifugation of homogeneous CsCl solutions at maximum allowable speeds (from Figure 4) results in gradients presented here.

For example, in the SW 32 Ti rotor, a *quarter-filled* tube of 1.69-g/mL homogeneous CsCl solution at 4°C may be centrifuged at 25 000 rpm (see Figure 2). The segment of the 25 000 rpm curve (Figure 3) from the quarter-filled line to r_{\max} (the tube bottom) represents this gradient. The same solution in a *half-filled* tube may be centrifuged no faster than 17 000 rpm, and 15 000 rpm in a *three-quarter-filled* tube. A tube *full* of the 1.69-g/mL CsCl solution may be centrifuged no faster than 13 500 rpm. Curves not shown in the figures may be interpolated.

TYPICAL EXAMPLES FOR DETERMINING RUN PARAMETERS



Example A: Starting with a homogeneous CsCl solution density of 1.40 g/mL and approximate particle buoyant densities of 1.38 and 1.42 g/mL, at 20°C, where will particles band at equilibrium in the SW 32 Ti rotor?

1. In Figure 2, find the curve that corresponds to the required run temperature (20°C) and fill volume (three-quarters full). The maximum allowable rotor speed is determined from the point where this curve intersects the homogeneous CsCl density (28 000 rpm).
2. In Figure 3, sketch a horizontal line corresponding to each particle's buoyant density.
3. Mark the point in Figure 3 where each particle density intersects the curve corresponding to the selected run speed and temperature.
4. Particles will band at these locations across the tube diameter at equilibrium during centrifugation.

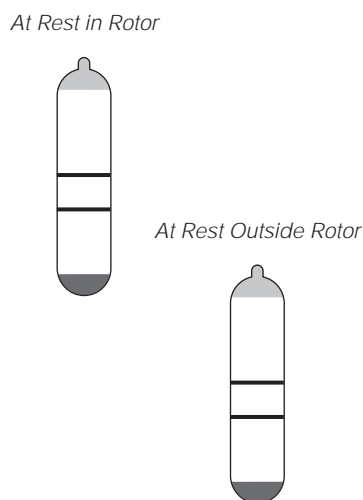

In this example, particles will band about 120 and 125 mm from the axis of rotation, about 5 mm of centerband-to-centerband separation.

To determine interband volume in milliliters, use the following equation:

$$V = \pi r^2 h \tag{7}$$

where r is the tube radius in centimeters and h is the interband separation in centimeters.

Example B: Knowing particle buoyant densities (for example, 1.55 and 1.50 g/mL), how do you achieve good separation in the SW 32.1 Ti rotor?

1. In Figure 5, sketch in a horizontal line corresponding to each particle's buoyant density.
2. Select the curve at the desired temperature (20°C) and tube volume (full) that gives the best particle separation.
3. Note the run speed along the selected curve (20 000 rpm).
4. From Figure 2, select the maximum homogeneous CsCl density (in this case, 1.56 g/mL) that corresponds to the temperature and run speed established above. These parameters will provide the particle-banding pattern selected in Step 2.

In this example, particles will band about 119.5 and 129 mm from the axis of rotation (about 9.5 mm apart).

CARE AND MAINTENANCE

MAINTENANCE

NOTE

Do not use sharp tools on the rotor that could cause scratches in the rotor surface. Corrosion begins in scratches and may open fissures in the rotor with continued use.

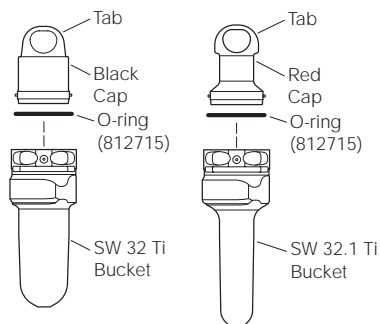

- Frequently check the bucket O-rings for signs of wear. Replace O-rings every 6 months, or whenever worn or damaged. Use the hooked removal tool (978354) to remove O-rings. Keep the O-rings lightly coated with silicone vacuum grease (335148).
- Regularly inspect the rotor body, buckets, and caps for cracks, pitting, or heavy discoloration.

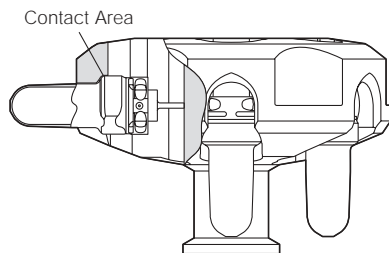

NOTE

Wear will become visible over time on the contact areas between buckets and rotor body. Such wear will not affect rotor operation.

- Frequently lubricate the bucket and cap mating surfaces with a thin, even coat of Spinkote lubricant (306812).

Refer to Appendix A of *Rotors and Tubes* for the chemical compatibility of rotor and accessory materials. Your Beckman Coulter representative provides contact with the Field Rotor Inspection Program and the rotor repair center.

CLEANING

Wash the rotor and rotor components immediately if salts or other corrosive materials are used or if spillage has occurred. Do not allow corrosive materials to dry on the rotor.

Under normal use, wash the rotor frequently (at least weekly, or after each run if runs are infrequent) to prevent buildup of residues.



1. Wash the rotor, buckets, O-rings, and caps in a mild detergent, such as Beckman Solution 555™, that won't damage the rotor. The Rotor Cleaning Kit (339558) contains two plastic-coated brushes and two quarts of Solution 555 (339555) for use with rotors and accessories. Dilute the detergent 10 to 1 with water.
2. Rinse the cleaned rotor and components with distilled water.
3. Air-dry the rotor and buckets upside down. Do not use acetone to dry the rotor.

Clean metal threads frequently to prevent buildup of residues and ensure adequate closure. Use a brush and concentrated Solution 555. Rinse and dry thoroughly, then lubricate lightly but evenly with Spinkote to coat all threads.

DECONTAMINATION



If the rotor or other components become contaminated with toxic, radioactive, or pathogenic substances, follow appropriate decontamination procedures as outlined by your laboratory safety officer. Refer to the chemical resistances list in Appendix A of *Rotors and Tubes* to select solutions that will not damage the rotor and accessory materials.

STERILIZATION AND DISINFECTION

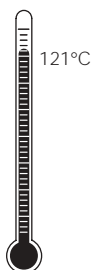

- The rotor and all rotor components can be autoclaved at 121°C for up to one hour. Remove the caps from the rotor buckets and place the rotor, buckets, caps, and spacers in the autoclave upside down.
- Ethanol (70%)¹ or hydrogen peroxide (6%) may be used on all rotor components, including those made of plastic. Bleach (sodium hypochlorite) may be used, but may cause discoloration of anodized surfaces. Use the minimum immersion time for each solution, per laboratory standards.

While Beckman Coulter has tested these methods and found that they do not damage components, no guarantee of sterility or disinfection is expressed or implied. When sterilization or disinfection is a concern, consult your laboratory safety officer.

Refer to publication IN-192 (included with each box of tubes) for tube sterilization and disinfection procedures. Quick-Seal, Ultra Clear and thinwall open-top tubes are disposable and should be discarded after a single use.

STORAGE

When it is not in use, store the rotor and buckets in a dry environment (not in the instrument). Remove the bucket caps to allow air circulation so that moisture will not collect in the buckets.

¹ Flammability hazard. Do not use in or near operating centrifuges.

RETURNING A ROTOR

Before returning a rotor or accessory for any reason, prior permission (a Returned Goods Authorization form) must be obtained from Beckman Coulter, Inc. This RGA form may be obtained from your local Beckman Coulter sales office, and should contain the following information:

- serial number of rotor,
- history of use (approximate frequency of use),
- reason for the return,
- original purchase order number, billing number, and shipping number, if possible,
- name and phone number of the person to be notified upon receipt of the rotor or accessory at the factory, and
- name and phone number of the person to be notified about repair costs, etc.

To protect our personnel, it is the customer's responsibility to ensure that the parts are free from pathogens and/or radioactivity. Sterilization and decontamination must be done before returning the parts. Smaller items (such as tubes, bottles, etc.) should be enclosed in a sealed plastic bag.

*All parts must be accompanied by a note, plainly visible on the outside of the box or bag, stating that they are safe to handle and that they are not contaminated with pathogens or radioactivity. **Failure to attach this notification will result in return or disposal of the items without review of the reported problem.***

Use the address label printed on the RGA form when mailing the rotor and/or accessories to:

Beckman Coulter, Inc.
1050 Page Mill Road
Palo Alto, CA 94304

Attention: Returned Goods

Customers located outside the United States should contact their local Beckman Coulter office.

SUPPLY LIST

NOTE

To receive copies of referenced publications, contact Beckman Coulter, Inc., Technical Publications Department, 1050 Page Mill Road, Palo Alto, CA 94304, U.S.A. (Telephone 650-859-1753; Fax 650-859-1375).

Contact Beckman Coulter Sales (1-800-742-2345 in the United States; worldwide offices are listed on the back cover of this manual) or see the Beckman Coulter *Ultracentrifuge Rotors, Tubes & Accessories* catalog (BR-8101, available at www.beckmancoulter.com) for detailed information on ordering parts and supplies. For your convenience, a partial list is given below.

REPLACEMENT ROTOR PARTS

SW 32 Ti rotor assembly	369650
SW 32 Ti buckets (set of 6, black, with caps and O-rings)	369647
SW 32 Ti bucket O-ring	812715
SW 32 Ti cap (black)	369643
SW 32.1 Ti rotor assembly	369651
SW 32.1 Ti buckets (set of 6, red, with caps and O-rings)	369648
SW 32.1 Ti bucket O-ring	812715
SW 32.1 Ti cap (red)	369645
Rotor stand	332400
Overspeed disk (32 000 rpm)	335456

OTHER

Tubes and accessories	see Tables 1 and 2
Bucket holder rack	331186
Quick-Seal Cordless Tube Topper Kit, 60 Hz	358312
Quick-Seal Cordless Tube Topper Kit, 50 Hz (Europe)	358313
Quick-Seal Cordless Tube Topper Kit, 50 Hz (Great Britain)	358314
Quick-Seal Cordless Tube Topper Kit, 50 Hz (Australia)	358315
Quick-Seal Cordless Tube Topper Kit, 50 Hz (Canada)	367803
Tube racks for the Tube Topper	
for 16-mm diameter tubes	348123
for 38-mm diameter tubes	348124
OptiSeal tube rack	361646
Tube removal tool	361668

Extractor tool (konical tube adapters)	354468
Silicone vacuum grease (1 oz)	335148
Spinkote lubricant (2 oz)	306812
Rotor Cleaning Kit	339558
Beckman Solution 555 (1 qt)	339555
Rotor cleaning brush	339379
Hooked O-ring removal tool	978354

ULTRACENTRIFUGE ROTOR WARRANTY

All Beckman Coulter ultracentrifuge Fixed Angle, Vertical Tube, Near Vertical Tube, Swinging Bucket, and Airfuge rotors are warranted against defects in materials or workmanship for the time periods indicated below, subject to the Warranty Conditions stated below.

Preparative Ultracentrifuge Rotors 5 years — No Proration

Analytical Ultracentrifuge Rotors 5 years — No Proration

ML and TL Series Ultracentrifuge Rotors 5 years — No Proration

Airfuge Ultracentrifuge Rotors 1 year — No Proration

For Zonal, Continuous Flow, Component Test, and Rock Core ultracentrifuge rotors, see separate warranty.

Warranty Conditions (as applicable)

- 1) This warranty is valid for the time periods indicated above from the date of shipment to the original Buyer by Beckman Coulter or an authorized Beckman Coulter representative.
- 2) This warranty extends only to the original Buyer and may not be assigned or extended to a third person without written consent of Beckman Coulter.
- 3) This warranty covers the Beckman Coulter Centrifuge Systems only (including but not limited to the centrifuge, rotor, and accessories) and Beckman Coulter shall not be liable for damage to or loss of the user's sample, non-Beckman Coulter tubes, adapters, or other rotor contents.
- 4) This warranty is void if the Beckman Coulter Centrifuge System is determined by Beckman Coulter to have been operated or maintained in a manner contrary to the instructions in the operator's manual(s) for the Beckman Coulter Centrifuge System components in use. This includes but is not limited to operator misuse, abuse, or negligence regarding indicated maintenance procedures, centrifuge and rotor classification requirements, proper speed reduction for the high density of certain fluids, tubes, and tube caps, speed reduction for precipitating gradient materials, and speed reduction for high-temperature operation.
- 5) Rotor bucket sets purchased concurrently with or subsequent to the purchase of a Swinging Bucket Rotor are warranted only for a term co-extensive with that of the rotor for which the bucket sets are purchased.
- 6) This warranty does not cover the failure of a Beckman Coulter rotor in a centrifuge not of Beckman Coulter manufacture, or if the rotor is used in a Beckman Coulter centrifuge that has been modified without the written permission of Beckman Coulter, or is used with carriers, buckets, belts, or other devices not of Beckman Coulter manufacture.
- 7) Rotor parts subject to wear, including but not limited to rotor O-rings, VTi, NVT™, TLV, MLN, and TLN rotor tube cavity plugs and gaskets, tubing, tools, optical overspeed disks, bearings, seals, and lubrication are excluded from this warranty and should be frequently inspected and replaced if they become worn or damaged.
- 8) Keeping a rotor log is not mandatory, but may be desirable for maintenance of good laboratory practices.

Repair and Replacement Policies

- 1) If a Beckman Coulter rotor is determined by Beckman Coulter to be defective, Beckman Coulter will repair or replace it, subject to the Warranty Conditions. A replacement rotor will be warranted for the time remaining on the original rotor's warranty.
- 2) If a Beckman Coulter centrifuge is damaged due to a failure of a rotor covered by this warranty, Beckman Coulter will supply free of charge (i) all centrifuge parts required for repair (except the drive unit, which will be replaced at the then current price less a credit determined by the total number of revolutions or years completed, provided that such a unit was manufactured or rebuilt by Beckman Coulter), and (ii) if the centrifuge is currently covered by a Beckman Coulter warranty or Full Service Agreement, all labor necessary for repair of the centrifuge.
- 3) If a Beckman Coulter rotor covered by this warranty is damaged due to a malfunction of a Beckman Coulter ultracentrifuge covered by an Ultracentrifuge System Service Agreement, Beckman Coulter will repair or replace the rotor free of charge.
- 4) If a Beckman Coulter rotor covered by this warranty is damaged due to a failure of a Beckman Coulter tube, bottle, tube cap, spacer, or adapter, covered under the Conditions of this Warranty, Beckman Coulter will repair or replace the rotor and repair the instrument as per the conditions in policy point (2) above, and the replacement policy.
- 5) Damage to a Beckman Coulter rotor or instrument due to the failure or malfunction of a non-Beckman Coulter tube, bottle, tube cap, spacer, or adapter is not covered under this warranty, although Beckman Coulter will assist in seeking compensation under the manufacturer's warranty.

Disclaimer

IT IS EXPRESSLY AGREED THAT THE ABOVE WARRANTY SHALL BE IN LIEU OF ALL WARRANTIES OF FITNESS AND OF THE WARRANTY OF MERCHANTABILITY AND BECKMAN COULTER, INC. SHALL HAVE NO LIABILITY FOR SPECIAL OR CONSEQUENTIAL DAMAGES OF ANY KIND WHATSOEVER ARISING OUT OF THE MANUFACTURE, USE, SALE, HANDLING, REPAIR, MAINTENANCE, OR REPLACEMENT OF THE PRODUCT.

Factory Rotor Inspection Service

Beckman Coulter, Inc., will provide free mechanical and metallurgical inspection in Palo Alto, California, USA, of any Beckman Coulter rotor at the request of the user. (Shipping charges to Beckman Coulter are the responsibility of the user.) Rotors will be inspected in the user's laboratory if the centrifuge in which they are used is covered by an appropriate Beckman Coulter Service Agreement. Contact your local Beckman Coulter office for details of service coverage or cost.

Before shipping, contact the nearest Beckman Coulter Sales and Service office and request a Returned Goods Authorization (RGA) form and packaging instructions. Please include the complete rotor assembly, with buckets, lid, handle, tube cavity caps, etc. A SIGNED STATEMENT THAT THE ROTOR AND ACCESSORIES ARE NON-RADIOACTIVE, NON-PATHOGENIC, NON-TOXIC, AND OTHERWISE SAFE TO SHIP AND HANDLE IS REQUIRED.

Beckman Coulter Worldwide Biomedical Research Division Offices

AUSTRALIA

Beckman Coulter Australia Pty Ltd
Unit D, 24 College St.
Gladesville, NSW 2111
Australia
Telephone: (61) 2 9844-6000
or toll free: 1 800 060 880
Fax: (61) 2 9844-6096
email: lifescienceaustralia@beckman.com

CANADA

Beckman Coulter (Canada) Inc.
6755 Mississauga Road, Suite 600
Mississauga, Ontario
Canada L5N 7Y2
Telephone: (905) 819-1234
Fax: (905) 819-1485

CHINA

Beckman Coulter Inc.
Beijing Representative Office
Unit 2005A, 2006-2009, East Ocean Center
Jian Guomenwai Avenue
Beijing 100004
China
Telephone: (86) 10 6515 6028
Fax: (86) 10 6515 6025, 6515 6026

EASTERN EUROPE/ MIDDLE EAST/NORTH AFRICA

Beckman Coulter International S.A.
22, Rue Juste-Olivier
Case Postale 301-303
CH-1260 Nyon, Switzerland
Telephone: (41) 22 994 07 07
Fax: (41) 22 994 07 00

FRANCE

Beckman Coulter France S.A.
Paris Nord II, 33/66 rue des Vanesses
B.P. 50359
Villepinte, France
95942 ROISSY CDG Cedex
Telephone: 01 49 90 90 00
Fax: 01 49 90 90 10
e-mail: bioresearch.france@beckman.com

GERMANY

Beckman Coulter GmbH
Europark Fichtenhain B-13
47807 Krefeld
Germany
Telephone: 49 21 513335
Fax: 49 21 51333633
e-mail: bioresearch.de@beckman.com

HONG KONG

Beckman Coulter Hong Kong Ltd.
12th Floor, Oxford House
979 King's Road
Taikoo Place, Hong Kong
Telephone: (852) 2814 7431, 2814 0481
Fax: (852) 2873 4511

ITALY

Beckman Coulter S.p.a.
Centro Direzionale Lombardo
Palazzo F/1, Via Roma 108
20060 Cassina de' Pecchi
Milano, Italy
Telephone: 02-953921
Fax: 02-95392264

JAPAN

Beckman Coulter K.K.
Toranomon 37 Mori Bldg.
3-5-1, Toranomon
Minato-ku, Tokyo 105-0001
Japan
Telephone: 03-5404-8359
Fax: 03-5404-8436

MEXICO

Beckman Coulter de Mexico S.A. DE C.V.
Avenida Popocatepetl #396
Colonia Gral. Pedro Maria Anaya
Codigo Postal 03340
Mexico, D.F. Mexico
Telephone: 525 605-77-70
Fax: 525 575-18-25

NETHERLANDS

Beckman Coulter Nederland B.V.
Nijverheidsweg 21
3641 RP-Mijdrecht
Postbus 47
3640 AA Mijdrecht
The Netherlands
Telephone: 0297-230630
Fax: 0297-288082

SINGAPORE

Beckman Coulter Singapore Pte. Ltd.
116 Changi Road
Unit #03-01/02
Singapore 419718
Telephone: (65) 6339 3633
Fax: (65) 6336 6303

SOUTH AFRICA/SUB-SAHARAN AFRICA

Beckman Coulter
Stand 1A Primegro Park
Tonetti Street
1685 Halfway House
Johannesburg
Republic of South Africa
Telephone: (27) 11-805-2014/5
Fax: (27) 11-805-4120
e-mail: beckman@intekom.co.za

SPAIN

Beckman Coulter España S.A.
C/ Caleruega, 81
28033 Madrid, Spain
Telephone: 91 3836080
Fax: 91 3836096
email: bioresearch.espana@beckman.com

SWEDEN

Beckman Coulter AB
Archimedesvaegen 7
Box 111 56
SE-168 11 Bromma
Sweden
Telephone: (0)8 564 85 900
Telefax: (0)8 564 85 901

SWITZERLAND

Beckman Coulter International S.A.
22, Rue Juste-Olivier
Case Postale 301-303
CH-1260 Nyon
Switzerland
Telephone: 0800 850 810
Fax: 0848 850 810

TAIWAN

Beckman Coulter Taiwan Inc.
Taiwan Branch
8th Floor
216 Tun Hwa South Road, Section 2
Taipei 106, Taiwan
Republic of China
Telephone: (886) 2 2378 3456
Fax: (886) 2 2377 0408

TURKEY

Beckman Coulter Ltd.
E-5 Yanyol Faith Cad.
81410 Soganklik Kartal
Istanbul
Turkey
Telephone: 90 216 309 1900
Fax: 90 216 309 0090

UNITED KINGDOM

Beckman Coulter United Kingdom Ltd
Oakley Court
Kingsmead Business Park
London Road
High Wycombe
Buckinghamshire HP11 1JU
England, U.K.
Telephone: 01494 441181
Fax: 01494 447558
e-mail: beckman_uk@beckman.com

Authorized dealers in other countries.



Beckman Coulter, Inc. • 4300 N. Harbor Boulevard, Box 3100 • Fullerton, California 92834-3100
Sales: 1-800-742-2345 • Service: 1-800-551-1150 • Internet: www.beckmancoulter.com • Telex: 678413 • Fax: 1-800-643-4366

